



# WE DRIVE SLAR







Europese primeur: 1e bidirectionele laadpaal

Slechts 8.500 bidirectionele auto's nodig om heel Utrecht van energie te voorzien

Er zijn meer dan 130.000 auto's in Utrecht





21 maart 2019: wereldpremière bidirectioneel ecosysteem



Utrecht eerste stad ter wereld: 400 bidirectionele publieke laadpalen



Worlds largest bidirectional charging plaza



ASR:  
de nederlandse  
verzekerings  
maatschappij  
voor alle  
verzekerings

2.170 zonnepanelen  
op bi-directionele  
laadgarage



ASR: largest V2G-charging-plaza in the world



# 1000 SION

WILL BE PROVIDED FOR  
V2G PROJECT IN UTRECHT



First IONIQ 5: testing!

69 - 125





200 auto's in oa Utrecht, Arnhem, Zoetermeer, Den Haag, Rotterdam & Amsterdam



Car Sharing

WE DRIVE  LAR

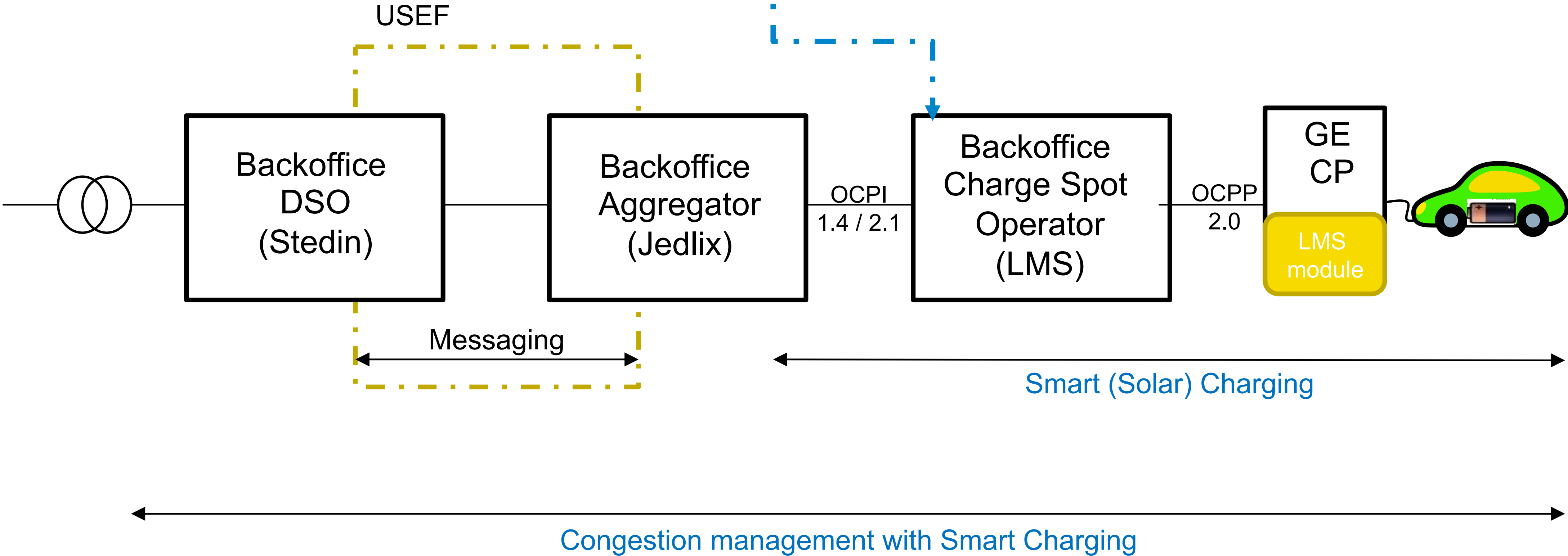



Cartesiusdriehoek: 200-400 deelauto's & e-bikes



mecanoo





200 zonnepanelen

Proeftuin Jaarbeurs P4



## Topnieuws



**Massale belangstelling voor getuigenis Astrid Holleeder: extra zaal geopend**



**'Postorderbedrijf voor drugs' gebruikte 3D-printers voor smokkel via dark web**



**Rellen in Madrid na dood Senegalese straatverkoper**

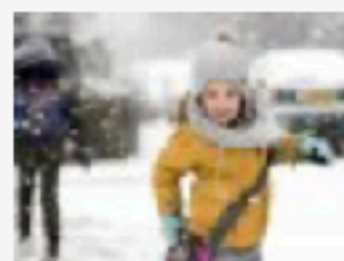

**▶ Het weekend wordt ijskoud met gevoelstemperatuur van min 10**



**Contract deelnemers Temptation Island**

 14 maart 2018 16:36

## Megabatterij in hartje Utrecht moet stad groener maken

 1  10  0 



Er zijn negen kasten geplaatst: acht powerpacks en één inverter. © Utrecht Marketing





1e Tesla Powerpack in NL: 400 kW, 800 kWh

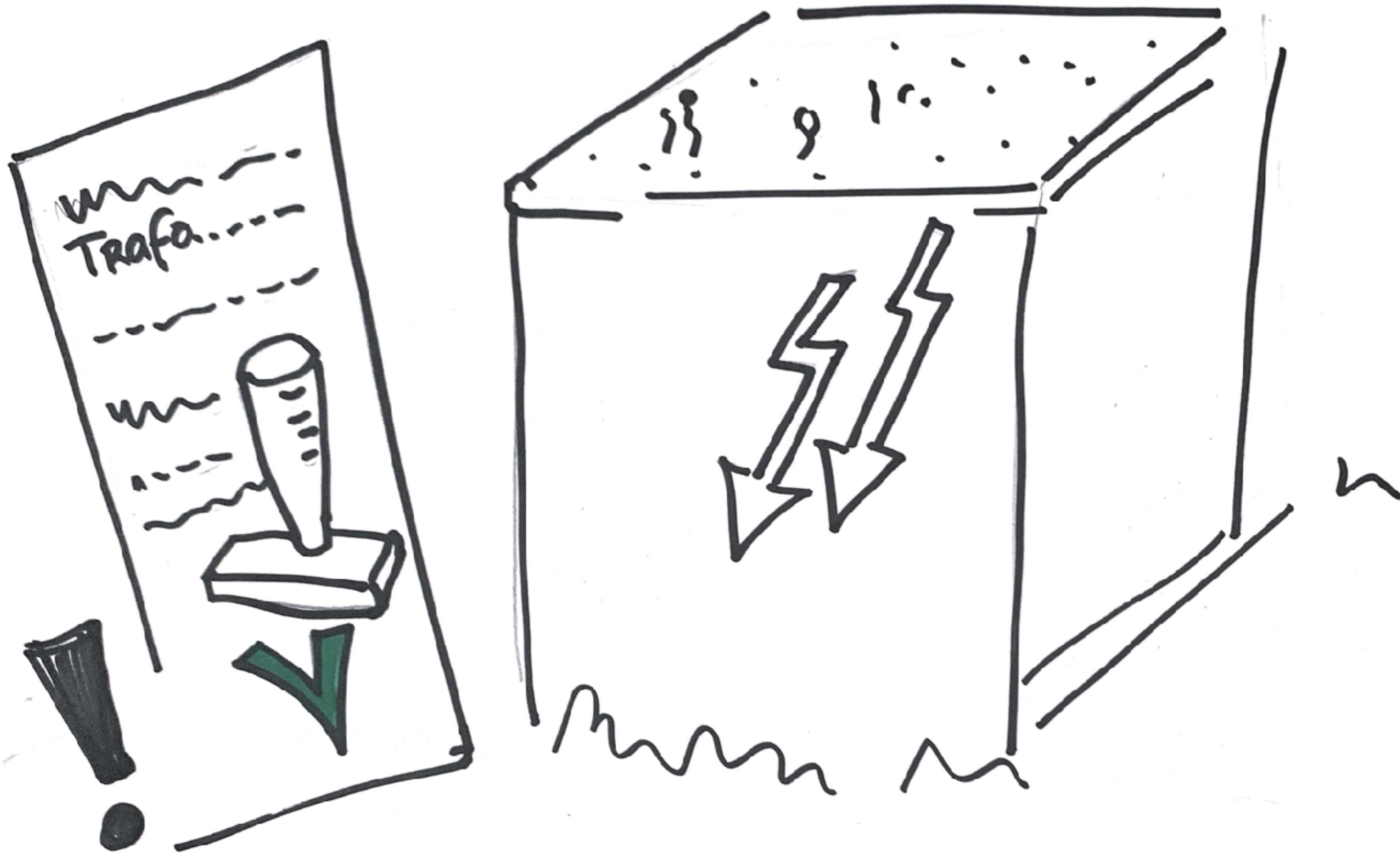

**IRIS**  
Smart cities

2e Powerpack in Kanaleneiland

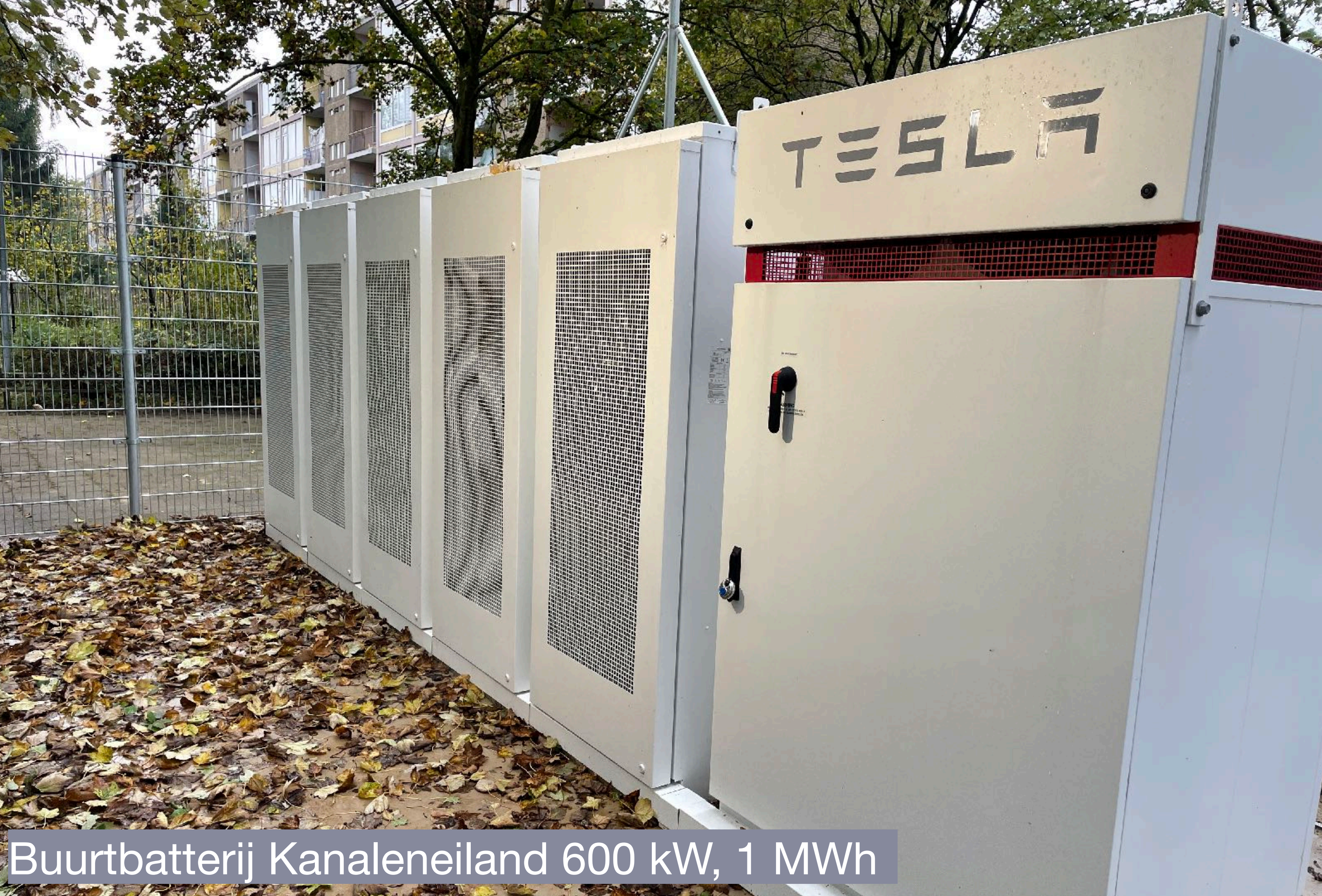

Buurtbatterij Kanaleneiland 600 kW, 1 MWh



**IRIS**  
Smart cities



# VERDIENMODELLEN PER MW PER JAAR

- Balanceringsreserves
  - FCR  $\pm\text{€ } 130.000 - 200.000$
  - aFRR  $\pm\text{€ } 180.000 - 280.000$
- Optimalisatie
  - Day-Ahead  $\pm\text{€ } 60.000 - 100.000$
  - Intraday  $\pm\text{€ } 60.000 - 100.000$
  - Onbalans  $\pm\text{€ } 80.000 - 180.000$
- Load shifting verschilt per type asset (zon, wind)
- Congestie verschilt per type asset (zon, wind)

Niet alle verdienmodellen kunnen gestapeld of gecombineerd worden!



Met dank aan Jan Willem van Zwang

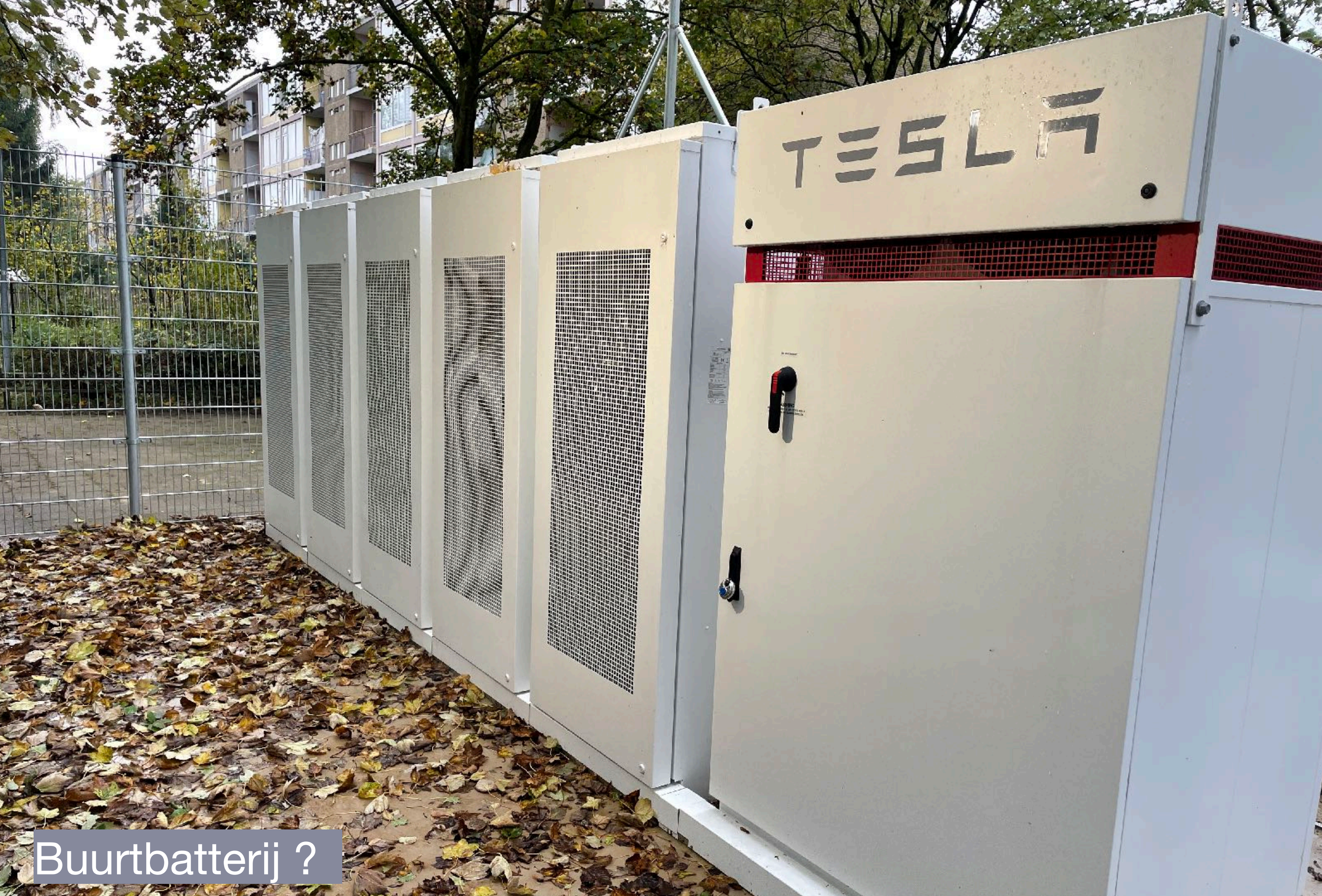

Buurtbatterij ?



**IRIS**  
Smart cities





**Dubbele energiebelasting verdwijnt!**

Energy Storage NL reageert verheugd op de  
afschaffing van de dubbele heffing bij ...

[energystoragenl.nl](https://energystoragenl.nl)

WE DRIVE LAR

